



TROLLEY 2P Lt. 30 "Black is Green"

TECHNICAL DATA SHEET

Range
mini trolleys

Date: June '24

Revision No.: 00



Item number	<u>CARR03523 0099</u>
Description	Trolley 2P "BIG" Lt.30, w/cassette and Speed wringer, 2-pack, <u>completely disassembled</u>
Dimensions	780 x 435 x 880 h [mm]
Weight	9 [Kg]
Plastic content recycled	54,7 %
Packaging dimensions	845 x 475 x 565 h [mm]
Packaging volume	0,227 [m ³]
Packaging	2 piece
Gross weight	20 [Kg]
Standard pallet	- Quantity: 10 boxes - Dimensions: 120 x 80 x 230 h [cm]. - Total unit: 20 pcs

MATERIALS USED	
<i>Trolley base (whole)</i>	Material: Recycled polypropylene
<i>Wringer support</i>	Material: Recycled polypropylene
<i>Wheels (4 pcs.)</i>	Ø 80, pivoting Metal support – Plastic thread guards, coverage thermoplastic rubber
<i>Bumpers (4 pcs.)</i>	Material: Polypropylene
<i>Bucket It. 15 (1+1 pcs.)</i>	Material: Recycled polypropylene Handle: Polypropylene
<i>Speed wringer</i>	Material: Handle: Aluminium Knob: PVC Structure: polypropylene Skrits: recycled polypropylene Thrust pad: Nylon + Fibre Glass Pressure pad: polypropylene Piston rods: Nylon + Fibre Glass Torsion spring: Steel
<i>Reversible handle with pins</i>	Radiated tubular 30x15 Anti-corrosion treatment: Painting Material: Steel E235 + CR1 Pins: in Acetal Resin
<i>Handle box with hooks</i>	Material: Polypropylene and recycled Dimensions: 150 x 300 x 155 h mm Couplings: in acetal resin

The data indicated in this technical sheet are to be considered indicative; the manufacturer reserves the right to change the data listed above without notice.

Guide de montage

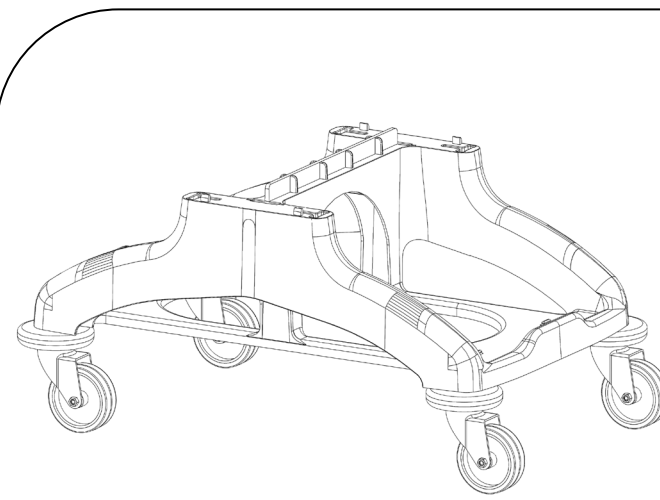
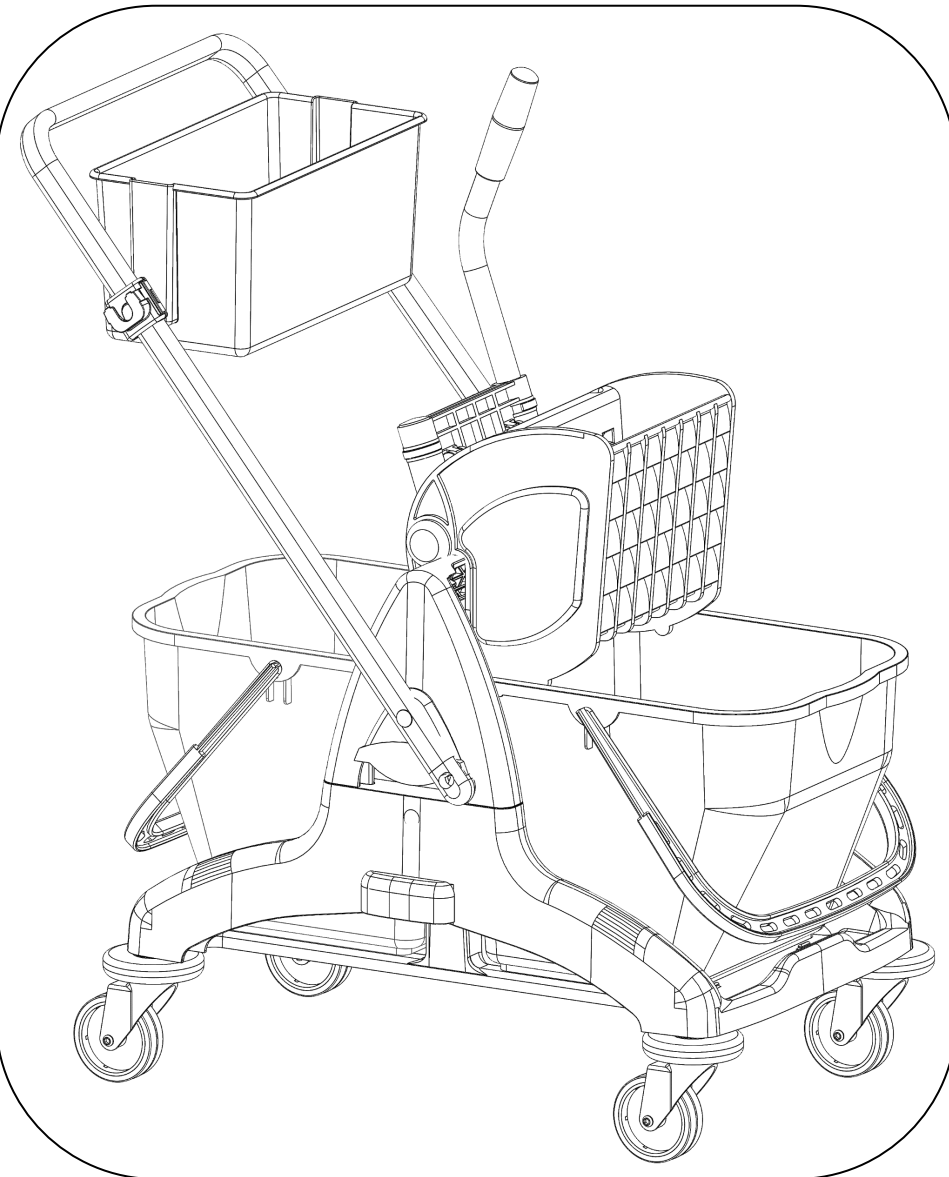

Base intera
2P lt. 30/50
con 4 ruote
d.80 mm in
metallo
*2P trolley
base lt.30/50
with 4 metal
castors d.80
mm*

PCS. 1

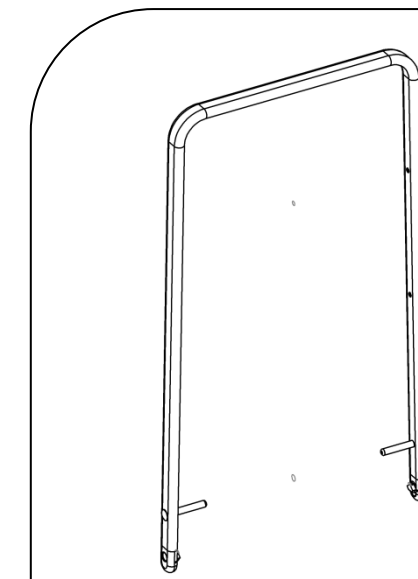

Maniglia reversibile
verniciata completa
di 2 perni

*Varnished
reversible
handle with 2
linking pins*

PCS. 1

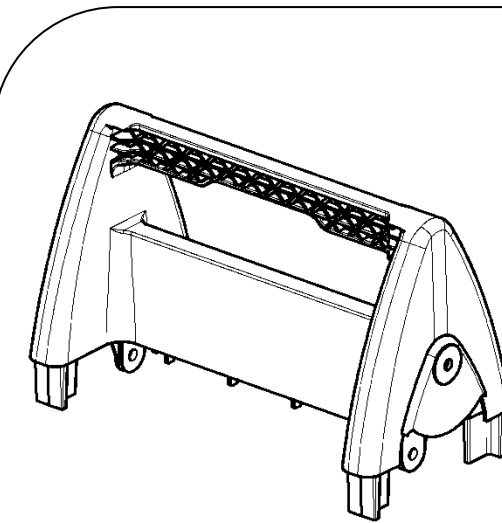

Supporto
strizzatore

*Mop wringer
support*

PCS. 1

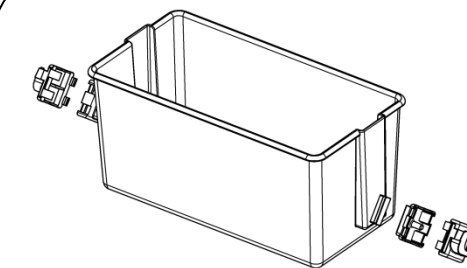

Cassetta per maniglia
con supporti

Handle tray

PCS. 1

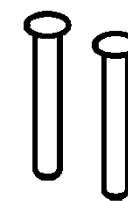

Perno tondo fissaggio supporto
strizzatore 3P

*Linking pins for fixing mop
wringer support*

PCS. 2

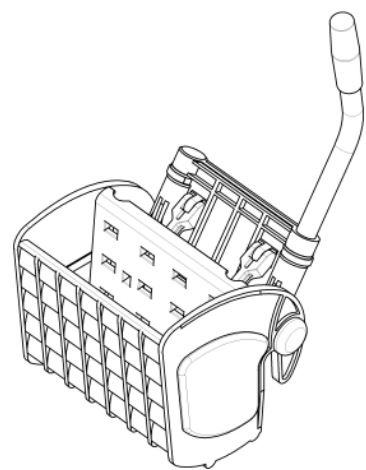

Strizzatore Speed

Speed wringer

PCS. 1

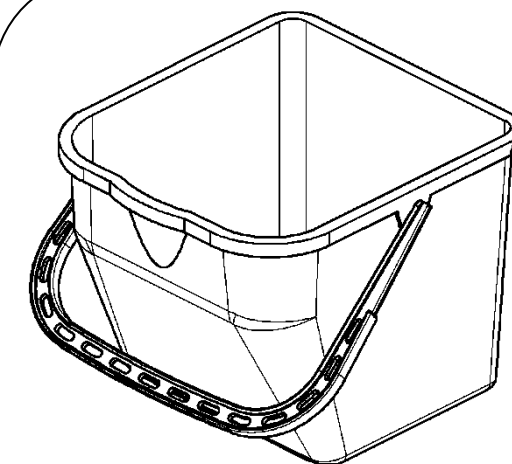

Secchio lt.15

Bucket lt.15

PCS. 2

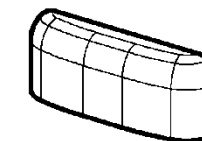

Mostrina copricoda
di rondine
*Plastic top for dovetail
joint for 3P trolley base*

PCS. 1

